

USBCAN-Mini

USB to CAN adapter

User Manual



Ver.: V3.01 (2015/04/22)

Revision History:

Ver.	Date	Reason
V1.00	2013/6/16	Create document
V2.01	2013/12/20	Fixed working parameters
V3.01	2015/04/22	Add some parameters

Contents

Contents	3
1. Introduction.....	4
1.1 Functional Overview	4
1.2 Properties at a Glance	4
1.3 Typical application	4
2. Installation.....	5
2.1 Driver and software installation.....	5
2.2 Connect to PC	5
2.3 Connect to CAN-Bus	5
3. Adapter in use	7
3.1 Connect to USB	7
3.2 Connect to CAN.....	7
3.3 CAN-Bus terminal resistance	7
3.4 System LED	8
4. ECAN Tools introduction	9
4.1 Start	9
4.2 Transmit/Receive data.....	9
4.3 CAN-Bus diagnosis function	10
4.4 Statistics mode	10
4.5 Other functions.....	11
5. Secondary development	12
6. Technical Specifications	13
Appendix: CAN2.0B frame format.....	14
Sales	16

1. Introduction

1.1 Functional Overview

USBCAN-Mini adapter is a debugging or analysis tool with one CAN-Bus channel. This adapter is development for portable use. Using this adapter, PC can easily connect to CAN-Bus network through USB interface, and become a intelligent node of CAN-Bus to transmit/receive CAN-Bus data.

Adapter comes with isolation, and can be used in different Windows systems. Device driver, software and programming interfaces(VC, VB, Net, Delphi, Labview, C++Builder) exist for different operating systems, so programs can easily access a connected CAN-Bus.

1.2 Properties at a Glance

- Adapter for USB connection (USB 1.1, compatible with USB 2.0)
- USB voltage supply
- Bit rates up to 1 Mbit/s Time stamp resolution 1 μ s
- Compliant with CAN specifications 2.0A (11-Bit ID) and 2.0B (29-Bit ID)
- CAN-Bus connection via DB9
- NXP SJA1000 CAN controller
- NXP PCA82C251 CAN transceiver
- Support ECAN Tools software
- Galvanic isolation on the CAN connection up to 1500 V
- Extended operating temperature range from -40 to 85 °C
- Device driver and software support Windows 2000/2003/XP/7/8/10
- Size: (L)55mm * (W)35mm * (H)14mm, wire 0.9m

1.3 Typical application

- Test CAN-Bus network or device
- CAN-Bus bootloader development
- Automotive data decoding tool
- Electrical system communication test
- Analysis of Vehicle Fault Diagnosis
- ECU data simulation
- Listen all CAN-Bus communication

2. Installation

This chapter describes how to connect the USB-CAN adapter to the computer and the precautions when connecting the USB-CAN adapter to the computer for the first time.

2.1 Driver and software installation

Note: Before install the driver or software, please ensure that the user login windows account is administrator, or the user account has to install the driver and software related permissions, otherwise it may lead to the installation failed.

2.1.1 Install driver and software

ECAN Tools has been integrated hardware driver installation program, users can directly install ECAN Tools.

If you only need to install the driver, please enter the “driver” folder, select the installation file that corresponds to the system type. (“DriverSetup.exe” for 32-bit. “DriverSetup64.exe” for 64-bit)

2.1.2 Uninstall driver and software

Users can run the DriverSetup.exe/DriverSetup64.exe and click "Uninstall" button to uninstall the installed device driver.

2.2 Connect to PC

The adapter can be connected to a PC directly, if the USB power supply is insufficient, you need to use external power supply.

2.2.1 USB power supply mode

USB power supply mode is suitable for the most applications, such as: when USBCAN-Mini is the only device in USB port.

2.2.2 External power supply mode (only the USBCAN-II Pro support)

External power supply mode is suitable for the USB port using an USB HUB and have already connect multiple USB device, this will lead to the adapter lack of electricity supply.

2.3 Connect to CAN-Bus

USBCAN-Mini has one CAN-Bus by DB9 port, this CAN-Bus channels can connect to CAN-Bus network or devices. DB9 pin definition as Table 2.1 below.

Pin	Prot	Name	Function
1	CAN	+5V	+5V power supply(optional)
2		CAN_L	CAN_L signal line
3/6		CAN_G	CAN_GND signal line
7		CAN_H	CAN_H signal line
Others		NC	Not connect

Table 2.1 USBCAN-Mini adapter pin definition

Note: In practical use, most of the time just connected the CAN_H to CAN_H
 User Manual Shenyang Guangcheng Technology CO.LTD.

and CAN_L connected to CAN_L then communication can be realized

3. Adapter in use

3.1 Connect to USB

USBCAN-Mini adapter can conform to the USB2.0 full speed protocol specification, compatible USB1.1.

When driver and software have been installed, connect the adapter to the USB interface, a new USBCAN device named "GC - Tech USBCAN Device" can be found in the PC Device manager. If there is no "!" or "?" mark that the device runs fine.

3.2 Connect to CAN

USBCAN-Mini adapter connects to CAN-Bus as chapter 2.3, CAN_H to CAN_H, CAN_L to CAN_L.

The CAN bus network adopts a topological structure, only the two furthest terminals need to connect 120Ω terminal resistance between CAN_H and CAN_L. For branch connection, its length should not be more than 3m. CAN-bus nodes connection as shown in figure 3.1

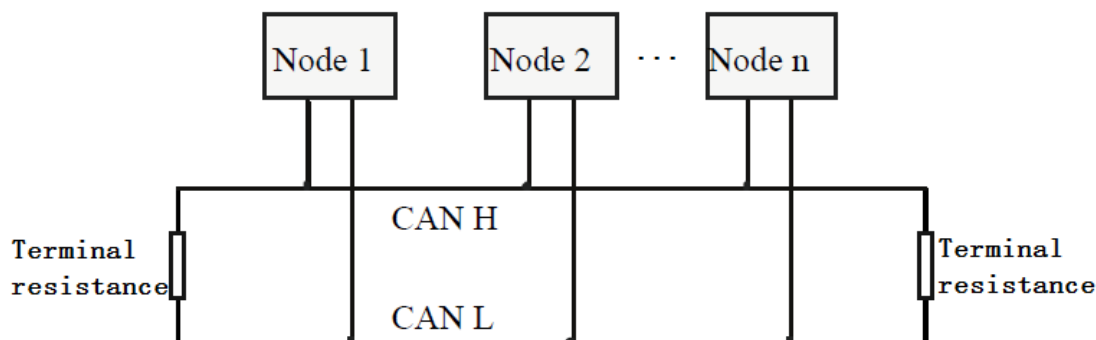

Figure 3.1 CAN-bus network

Note: the CAN-bus cable can use twisted-pair cable, shielded twisted-pair cable. Theory of the maximum communication distance depends on the bus baud rate, Their relationship as shown in the Table 3.1.

Baud rate	Distance
1 Mbit/s	40m
500 kbit/s	110m
250 kbit/s	240m
125 kbit/s	500m
50 kbit/s	1.3km
20 kbit/s	3.3km
10 kbit/s	6.6km
5 kbit/s	13km

Table 3.1 relationship of baud rate and distance

3.3 CAN-Bus terminal resistance

In order to improve the communication reliability and eliminate CAN-bus

terminal reflection, the two furthest terminal need to connect terminal resistance between CAN_H and CAN_L as shown in figure 3.2. Terminal resistance values determined by the characteristic impedance of the cables. Such as, the characteristic impedance is 120Ω.

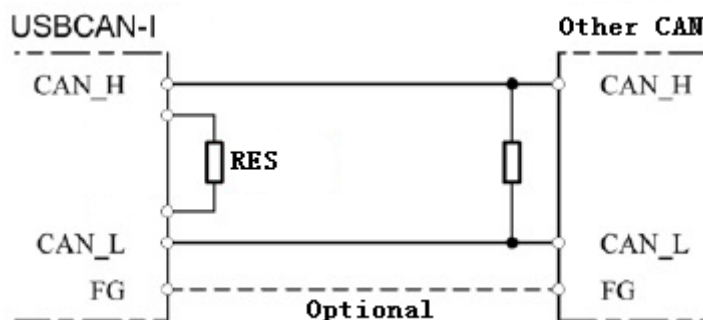

Figure 3.2 USBCAN-Mini connect to other CAN devices

Note: USBCAN-Mini adapter has none 120Ω terminal resistance inside.

3.4 System LED

USBCAN-Mini adapter with one bi-colour PWR indicator to indicate the adapter status. More functions are shown in table 3.2 and 3.3.

Indicator	Colour	State
PWR	Green	Power indicator
SYS	Green	System and data indicator

Table 3.2 USBCAN-Mini adapter indicator LED

When USBCAN-Mini adapter power on, the PWR indicator will light, indicates the adapter has power supply, the system is initialized; Otherwise, a system power failure or system errors has exist.

When the adapter has been opened by software, and CAN-Bus data transceiver, the SYS indicator will blinking.

Indicator	State	Meaning
PWR	On	Power on
SYS	Slow blinking	Initialize OK
	Fast blinking	CAN data transmission

Table 3.3 USBCAN-Mini adapter LED state

4. ECAN Tools introduction

Users can use ECAN Tools software to receive and transmit CAN data. Flexible use of functions can help to more with less.

4.1 Start

1. If ECAN Tools has been installed, users can directly run it on the desktop.



2. Choose the device type and click "open device", one adapter will shown in the below.

3. Choose work mode. Software provides three kinds of work mode: normal, listen, selftest.

Normal: use this mode to transmit or receive data.

Listen: use this mode to receive data only, and don't send response or clock.

Selftest: use this mode to test if the adapter is working well.

4. Choose baud rate according to the CAN-bus, don't match will lead to communication failed.

If you don't know the baud rate, you can use "automatic identification of baud rate" function to adapt.

4.2 Transmit/Receive data

Transmitting and receiving is the basic function of ECAN Tools, in this interface, users can directly see the received CAN data, and sent the data to CAN-bus.

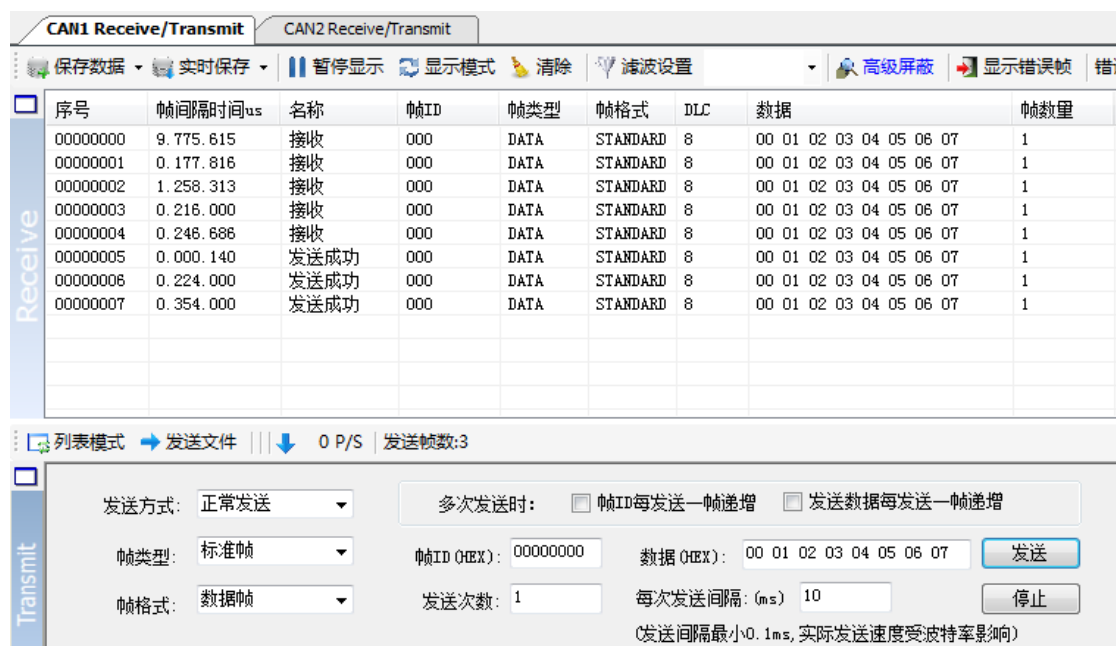

4.3 CAN-Bus diagnosis function

CAN-Bus diagnosis function can detect the bus error frames and bus arbitration lost.

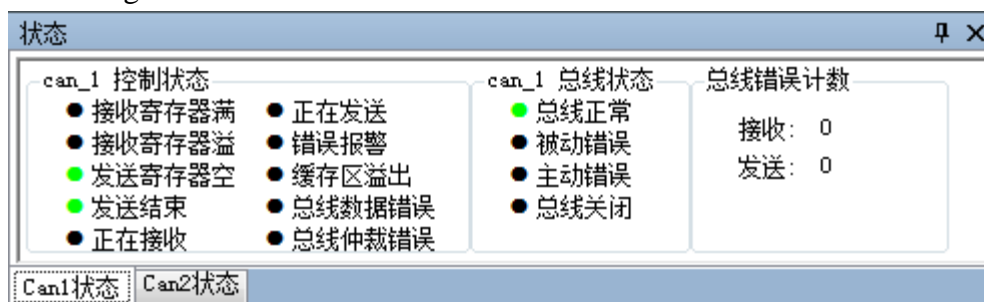

CAN bus status display: indicate the CAN bus status include: bus normal, passive error, active error、bus hung.

The CAN controller FIFO overflow: message within a certain period of time is too dense, lead to data loss.

The CAN controller error alarm: when many of errors on the bus, error counter exceeds the alarm threshold, and display the error count.

The CAN controller negative error: when many of send or receive errors, lead to the CAN controller into the negative state, and display the error count.

CAN bus controller error: when nodes send or receive errors, error counter value will be accumulate, and can catch the wrong information, such as ACK, CRC error and so on.

4.4 Statistics mode

When receiving data, software can classify these data in ID, data, name, format or type and counting the number of each data.

This function is suitable for large data systems, engineers can easily observe and analyze other data after same data is combined.

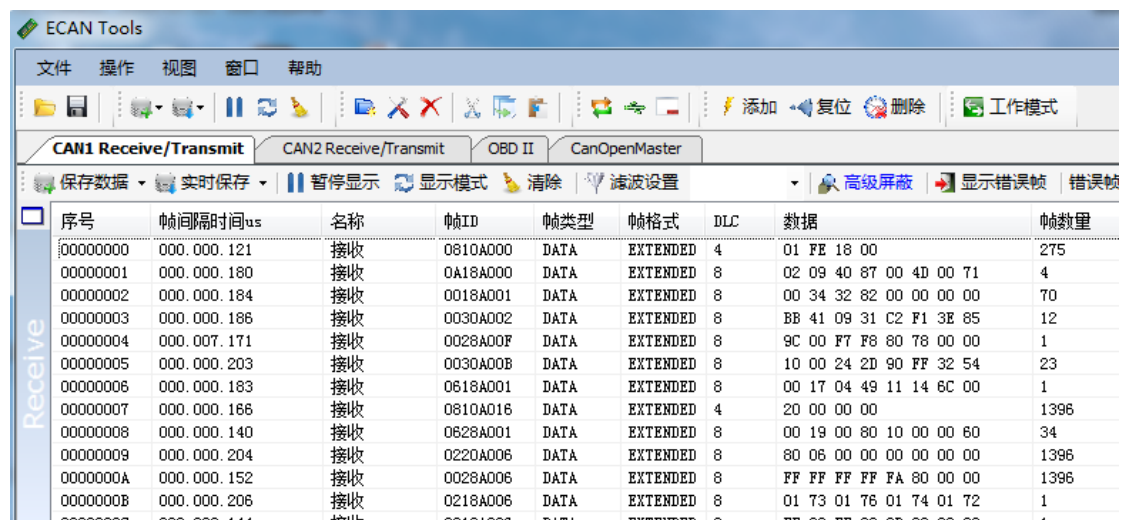

The screenshot shows the ECAN Tools software interface. The main window displays a table of received CAN frames. The table has the following columns: 序号 (Serial Number), 帧间隔时间us (Frame Interval Time in us), 名称 (Name), 帧ID (Frame ID), 帧类型 (Frame Type), 帧格式 (Frame Format), DLC (Data Length Code), 数据 (Data), and 帧数里 (Frame Count). The table lists 11 received frames, all of type '接收' (Receive) and 'EXTENDED' format. The data field shows hexadecimal values for each frame.

序号	帧间隔时间us	名称	帧ID	帧类型	帧格式	DLC	数据	帧数里
00000000	000.000.121	接收	0810A000	DATA	EXTENDED	4	01 FE 18 00	275
00000001	000.000.180	接收	0A18A000	DATA	EXTENDED	8	02 09 40 87 00 4D 00 71	4
00000002	000.000.184	接收	0018A001	DATA	EXTENDED	8	00 34 32 82 00 00 00 00	70
00000003	000.000.186	接收	0030A002	DATA	EXTENDED	8	BB 41 09 31 C2 F1 3E 85	12
00000004	000.007.171	接收	0028A00F	DATA	EXTENDED	8	9C 00 F7 F8 80 78 00 00	1
00000005	000.000.203	接收	0030A00B	DATA	EXTENDED	8	10 00 24 2D 90 FF 32 54	23
00000006	000.000.183	接收	0618A001	DATA	EXTENDED	8	00 17 04 49 11 14 6C 00	1
00000007	000.000.166	接收	0810A016	DATA	EXTENDED	4	20 00 00 00	1396
00000008	000.000.140	接收	0628A001	DATA	EXTENDED	8	00 19 00 80 10 00 00 60	34
00000009	000.000.204	接收	0220A006	DATA	EXTENDED	8	80 06 00 00 00 00 00 00	1396
0000000A	000.000.152	接收	0028A006	DATA	EXTENDED	8	FF FF FF FF FA 80 00 00	1396
0000000B	000.000.206	接收	0218A006	DATA	EXTENDED	8	01 73 01 76 01 74 01 72	1

4.5 Other functions

Save data: save the receiving list, save format: txt, can, csv and binary.

Display mode: scroll mode and list mode, list mode can classified data together according to the rules.

Filter settings: users can set multi-stage filtering by editing the filter ID.

Data mask: masked ID is not displayed.

Error frames: error frames on the bus can be displayed / hidden.

If you want to know more about the software specific function and usage, please see the “ECAN Tools software instructions” document.

5. Secondary development

We will provide interface, example and library for secondary development customers. Dll and library named: “ECANVCI.h” , “ECANVCI.lib” , “ECANVCI.dll” . These libraries standards compliant, users can use these in VC, VB and some other programming environment, to use these libraries, please see “ECAN dynamic library manual” and Figure 5.1.

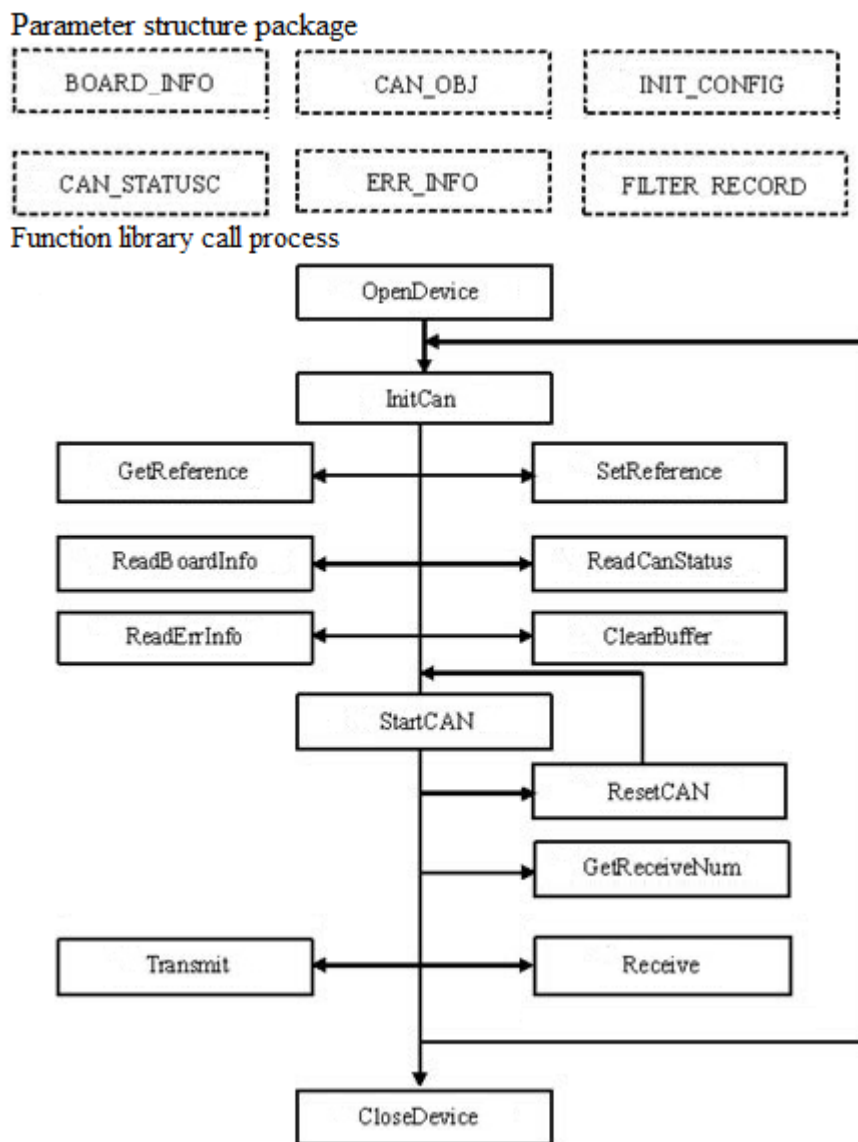

Figure 5.1 Secondary development function call process

6. Technical Specifications

Connection	
PC	USB, type A
CAN	DB9
Interface	
USB	USB2.0 full speed, USB 1.1
CAN	ISO 11898 standard, support CAN2.0A/B
CAN baud rate	5Kbit/s~1Mbit/s
Isolation	1500V, DC-DC
CAN terminal resister	Not integrated
Power	
Voltage	+5V DC (USB port)
Current	200mA (Max)
Environment	
Temperature	-40°C~+85°C
Humidness	15%~90%RH, without condensation
EMC test	EN 55024:2011-09 EN 55022:2011-12
IP grade	IP 20
Basic	
Size	55mm * 35mm * 14mm, wire 0.9m.
Weight	150g

Appendix: CAN2.0B frame format

CAN2.0B standard frame

CAN standard frame format is 11 bytes, including two parts: information and data.

The first 3 bytes for information.

Bit Byte	7	6	5	4	3	2	1	0
1	FF	RTR	×	×	DLC			
2	(Message identifier)				ID.10—ID.3			
3	ID.2—ID.0			×	×	×	×	×
4	data 1							
5	data 2							
6	data 3							
7	data 4							
8	data 5							
9	data 6							
10	data 7							
11	data 8							

Byte 1 for the frame information. Seventh (FF) means the frame format, in the standard frame, FF = 0; Sixth (RTR) means the type of frame, RTR = 0 means for the data frame, RTR = 1 for remote frame; DLC means the length of the data.

Byte 2, 3 for the message identifier.

Bytes 4~11 for the data of the data frame, remote frame is invalid.

CAN2.0B extended frame

CAN extended frame format is 13 bytes, including two parts: information and data.
The first 5 bytes for information.

Bit Byte	7	6	5	4	3	2	1	0
1	FF	RTR	×	×	DLC			
2	(Message identifier)				ID.28—ID.21			
3	ID.20—ID.13							
2	ID.12—ID.5							
3	ID.4—ID.0				×	×	×	
4	data 1							
5	data 2							
6	data 3							
7	data 4							
8	data 5							
9	data 6							
10	data 7							
11	data 8							

Byte 1 for the frame information. Seventh (FF) means the frame format, in the standard frame, FF = 0; Sixth (RTR) means the type of frame, RTR = 0 means for the data frame, RTR = 1 for remote frame; DLC means the length of the data.

Byte 2~5 for the message identifier.

Bytes 4~11 for the data of the data frame, remote frame is invalid.

Sales

Shenyang Guangcheng Technology CO.,LTD.

Address: Liaoning province, Shenyang, Huanggu District, Chongshan road no. 42

Postcode: 110000

QQ: 2881884588

E-mail: 2881884588@qq.com

Tel: +86 024-31230060

Fax: +86 024-31230070

Website: www.gcgd.net

