

# GCAN-403

High-speed CAN to fault-tolerant CAN converter

User manual



Document version: V3.20 (2018/07/18)

**revise history**

version	date	the reason
V1.00	2016/09/15	Create document
V2.01	2016/09/22	Correct equipment working parameters
V3.01	2016/10/10	Add some parameters
V3.02	2016/10/19	Correct some parameters
V3.20	2018/07/18	Adjust the document structure

## 目 录

1. Function introduction.....	4
1.1 Functional Overview.....	4
1.2 Performance characteristics .....	4
1.3 typical application.....	4
2. Equipment installation .....	5
2.1 Equipment size.....	5
2.2 Standard CAN interface description .....	5
2.3 Description of fault-tolerant CAN interface .....	6
3. Equipment use.....	7
3.1 Standard CAN connection .....	7
3.2 Fault-tolerant CAN connection.....	7
3.3 Standard CAN bus terminal resistance .....	7
3.4 System status indicator .....	8
4. General technical specifications .....	10
Appendix: Common standards, fault-tolerant CAN transceiver types .....	11
Sales and service .....	12

# 1. Function introduction

## 1.1 Functional Overview

Guangcheng Technology GCAN-403 fault-tolerant CAN converter provides a transparent conversion function between standard CAN (high-speed CAN) transceivers and fault-tolerant CAN transceivers that comply with the ISO/DIS11898-2/3 specification. The GCAN-403 converter integrates a fault-tolerant CAN transceiver and a standard CAN transceiver, and supports the mutual conversion of communication rates between 5Kbps and 125Kbps. The GCAN-403 converter can be used for testing and conversion of fault-tolerant CAN networks.

The GCAN-403 converter needs to be used with our company's DB9 interface standard CAN equipment. Users only need to connect the converter directly to the DB9 CAN bus interface to connect CAN analyzers, CAN conversion gateways, etc. to standard CAN transceivers. The device is converted into a fault-tolerant CAN transceiver and connected to a fault-tolerant CAN network.

## 1.2 Performance characteristics

- Integrated 1 standard CAN interface and 1 fault-tolerant CAN interface;
- Support CAN2.0A and CAN2.0B frame format, in line with ISO/DIS 11898 specification;
- The communication baud rate of the converter supports between 5Kbps~125Kbps;
- DC+5V 100mA power supply;
- Standard CAN interface adopts DB9 female (socket) interface;
- The fault-tolerant CAN interface adopts DB9 male (pin) interface;
- Operating temperature range: -40°C~+85°C;

## 1.3 typical application

- Standard CAN analyzer measures the fault-tolerant CAN bus;
- The CAN converter module is converted into a fault-tolerant CAN interface.

## 2. Equipment installation

The GCAN-403 converter uses the form of dual DB9 interfaces. The standard CAN device of the user using the DB9 interface can be directly connected to the converter through the DB9 interface to access the fault-tolerant CAN network.

### 2.1 Equipment size

The GCAN-403 converter uses engineering plastic packaging, and its dimensions: (length) 60mm \* (width) 32mm \* (height) 15mm.

The schematic diagram is shown in Figure 2.1.

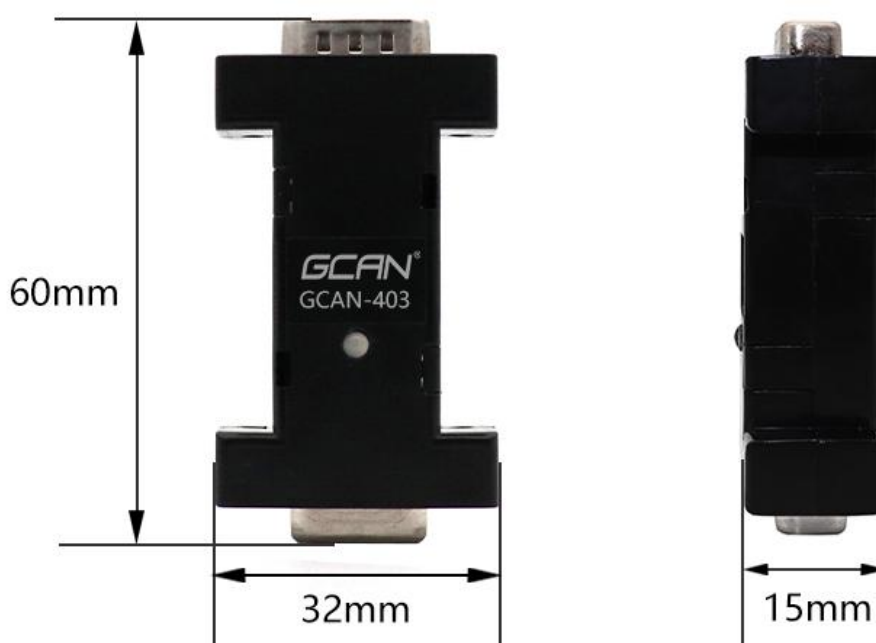

Figure 2.1 Dimensions of GCAN-403 converter

### 2.2 Standard CAN interface description

The standard CAN interface of GCAN-403 converter adopts the interface form of DB9 female (socket). Its interface definition complies with the German CiA standard. It can be directly connected to the DB9 male (pin) conforming to the CiA standard. The interface form of the converter As shown in Figure 2.2, the interface definition is shown in Table 2.1.

**Please note: When the GCAN-403 converter is working normally, it needs to be powered from pin 1 of the standard CAN interface before it can be used normally.**



Figure 2.2 CAN-bus signal distribution of GCAN-403 converter standard CAN

Pin (from left to right)	port	name	Features
2	High-speed CAN	CAN_L	CAN_L signal line (CAN low)
7		CAN_H	CAN_H signal line (CAN high)
1	power supply	+5V	5V power supply positive
3/6		GND	5V power supply GND
other		NC	Unused

Table 2.1 Definition of GCAN-403 converter standard CAN interface

### 2.3 Description of fault-tolerant CAN interface

The fault-tolerant CAN interface of GCAN-403 converter adopts the interface form of DB9 male (pin), and its interface definition conforms to the German CiA standard. It can be directly connected to the DB9 female (socket) conforming to the CiA standard. The interface form of the converter As shown in Figure 2.3, the interface definition is shown in Table 2.2.



Figure 2.3 GCAN-403 converter fault-tolerant CAN interface form

Pin (from left to right)	port	name	Features
2	Fault tolerance CAN	CAN_L	CAN_L signal line (CAN low)
3/6		CAN_GND	CAN_GND ground
7		CAN_H	CAN_H signal line (CAN high)
other		NC	Unused

Table 2.2 CAN-bus signal distribution of GCAN-403 converter fault-tolerant CAN

### 3. Equipment use

#### 3.1 Standard CAN connection

The GCAN-403 converter can be connected to standard CAN bus devices through the DB9 interface. Note that the standard CAN interface of the converter must have a 5V power supply.

#### 3.2 Fault-tolerant CAN connection

The GCAN-403 converter can be connected to fault-tolerant CAN bus devices through the DB9 interface.

#### 3.3 Standard CAN bus terminal resistance

The standard CAN bus network adopts a linear topology. In order to enhance the reliability of CAN communication and eliminate the interference of CAN bus terminal signal reflection, the two farthest ends of the CAN bus network usually need to add terminal matching resistors, as shown in Figure 3.1. The value of the terminal matching resistance is determined by the characteristic impedance of the transmission cable. For example, the characteristic impedance of the twisted pair is  $120\Omega$ , and the two terminals on the bus should also integrate  $120\Omega$  terminal resistance. If the number of nodes is greater than 2, the intermediate node does not need to install a  $120\Omega$  terminal resistor. For branch connections, the length should not exceed 3 meters. The connection of CAN bus devices is shown in Figure 3.2.

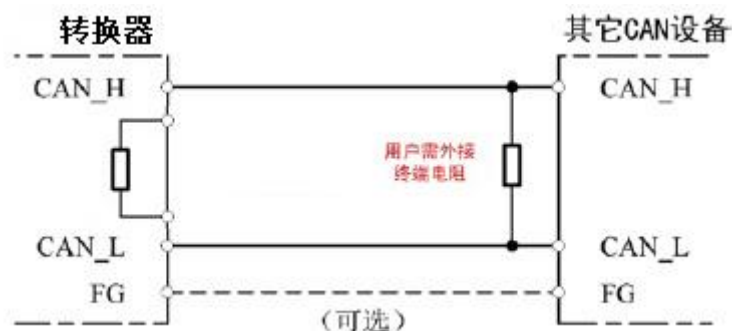

Figure 3.1 GCAN-403 converter standard CAN connection with other CAN node devices

Please note: The standard CAN bus side of the GCAN-403 converter has integrated a  $120\Omega$  terminal resistor.

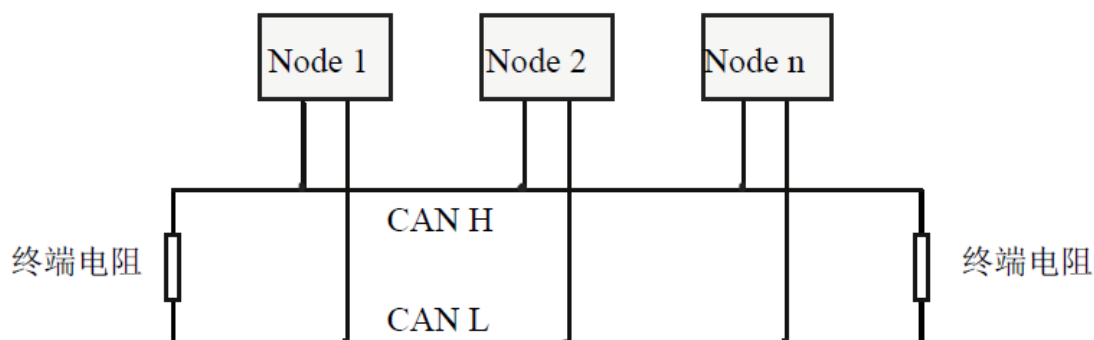

Figure 3.2 Topological structure of CAN bus network

Please note: CAN-bus cable can use ordinary twisted pair and shielded twisted pair. The theoretical maximum communication distance mainly depends on the bus baud rate. The relationship between the maximum bus length and the baud rate is shown in Table 3.1. If the communication distance exceeds 1Km, the cross-sectional area of the line should be greater than  $\Phi 1.0\text{mm}^2$ . The specific specifications should be determined according to the distance. The general rule is to increase the distance as the distance increases.

Baud rate	Bus length
1 Mbit/s	40m
500 kbit/s	110m
250 kbit/s	240m
125 kbit/s	500m
50 kbit/s	1.3km
20 kbit/s	3.3km
10 kbit/s	6.6km
5 kbit/s	13km

Table 3.1 Reference table of baud rate and maximum bus length

### 3.4 System status indicator

The GCAN-403 converter has an indicator light to indicate the operating status of the device. The indicator status and definition are shown in Table 3.2.

status	definition
not bright	The converter power supply is not normal
Steady green	Converter works fine
Flashing green	Converter has data conversion



Steady red	Converter generated error
------------	---------------------------

Table 3.2 GCAN-403 converter indicator

## 4. General technical specifications

<b>Connection method</b>	
Standard CAN terminal	DB9, female socket
Fault-tolerant CAN terminal	DB9, male pin
<b>Interface characteristics</b>	
CAN standard	Follow ISO 11898 standard, support CAN2.0A/B
Standard CAN baud rate	5Kbit/s~1Mbit/s
Fault-tolerant CAN baud rate	20Kbit/s~125Kbit/s
Standard CAN terminal resistance	1 integrated
<b>Power supply</b>	
Supply voltage	+5V DC
Supply current	Max 80mA
<b>Environmental test</b>	
Operating temperature	-40℃~+85℃
Working humidity	15%~90%RH, no condensation
Protection level	IP 20
<b>Basic Information</b>	
Dimensions	(Length) 63mm * (Width) 34mm * (Height) 16mm
weight	50g

## Appendix: Common standards, fault-tolerant CAN transceiver types



型号	CAN电平	通信速率/kbps	
PCA82C250	高速CAN	5-1000	
PCA82C251		5-1000	
TJA1040		60-1000	
TJA1041		60-1000	
TJA1044			
TJA1050		40-1000	
TJA1051		40-1000	
TJA1057			
MCP2551			
SN65HVD230			
AMIS-30660		5-1000	
AMIS-30663		5-1000	
AMIS-42700		5-1000	
CTM1050		60-1000	
CTM1051		5-1000	
CTM8250		5-1000	
CTM8251		5-1000	
CTM8251D			
PCA82C252		容错CAN	20-125
TJA1054			20-125
TJA1054A			
TJA1055	20-125		
TJA1055/3	20-125		
CTM1054			

## Sales and service

Shenyang Guangcheng Technology Co., Ltd.

Address: Industrial Design Center, No. 42 Chongshan

Middle Road, Huanggu District, Shenyang

City, Liaoning Province.

QQ: 2881884588

E-mail: 2881884588@qq.com

Tel: +86-024-31230060

Website: [www.gcgd.net](http://www.gcgd.net)

Sales and service Tel: +86-18309815706

After - sales service telephone Number: +86-13840170070

WeChat Number:13840170070