

GCAN-207

Professional 232/485-CAN converter

User Manual



Document version: V3.50 (2017/08/18)

Contents

1 Introduction.....	3
1.1 Overview.....	3
1.2 Properties at a glance.....	3
2 Installation.....	4
2.1 Connect to PC.....	4
2.2 Connect to CAN-Bus.....	4
2.3 Interface definition.....	4
2.4 System LED.....	5
3 Configuration instructions.....	7
3.1 Ready to configure.....	7
3.2 Software connection.....	7
3.3 Configure transformation parameters.....	7
3.4 Configure serial port parameters.....	9
3.5 Configure CAN parameters.....	9
4 Examples.....	11
4.1 Transparent conversion.....	11
4.2 Transparent conversion with identity.....	13
4.3 Format conversion.....	14
Sales and service.....	17

1 Introduction

1.1 Overview

The GCAN-207 converter has integrated one standard CAN-Bus interface, one Serial-Bus interface (RS232 or RS485). GCAN-207 converter can build a connection between Serial-Bus and CAN-Bus. With this converter, equipment that used Serial-Bus can connect to CAN-Bus without changing the hardware structure, this makes multi-Bus interconnection very flexible, and extends the application scope of CAN-Bus.

1.2 Properties at a glance

- Standard serial port level, RS232 model or RS485 model can switch by software
- Conversion direction can be set to: CAN \leftrightarrow Serial, CAN \leftarrow Serial, CAN \rightarrow Serial
- Serial Bus baud rate range from 600bps to 115200bps
- CAN-Bus supports CAN2.0A and CAN2.0B frame format, conform to ISO/DIS 11898 standards
- CAN-Bus baud rates range from 5Kbps to 1Mbps
- CAN-Bus interface with electrical isolation
- CAN-Bus isolation converter insulation voltage: DC 1500V
- Power supply: 9~30V(20mA, 24V DC)
- Installation method: DIN guide rail
- Working temperature range from -40 to 85 °C
- Size: (L)112mm * (W)70mm * (H)25mm

2 Installation

2.1 Connect to PC

The converter can be connected directly to a PC using an USB to RS232 cable.

If PC have RS232 port, using RS232 directly is also possible.

2.2 Connect to CAN-Bus

In practical use, connecting the CAN_H to CAN_H and CAN_L to CAN_L, then communication can be realized.

2.3 Interface definition

GCAN-207 converter port definition as shown in figure 2.1 and figure 2.2, using the terminal and the RS232 port, for industrial field application.

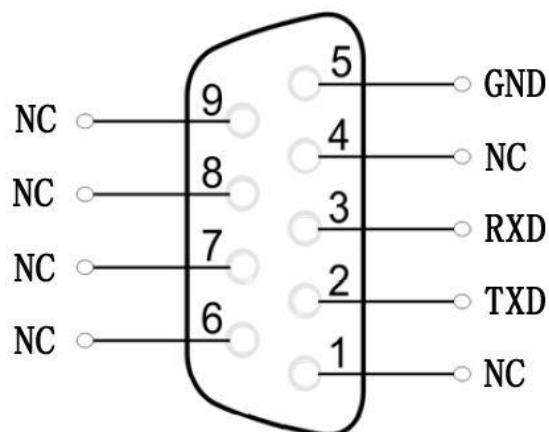

Figure 2.1 GCAN-207 RS232 port definition

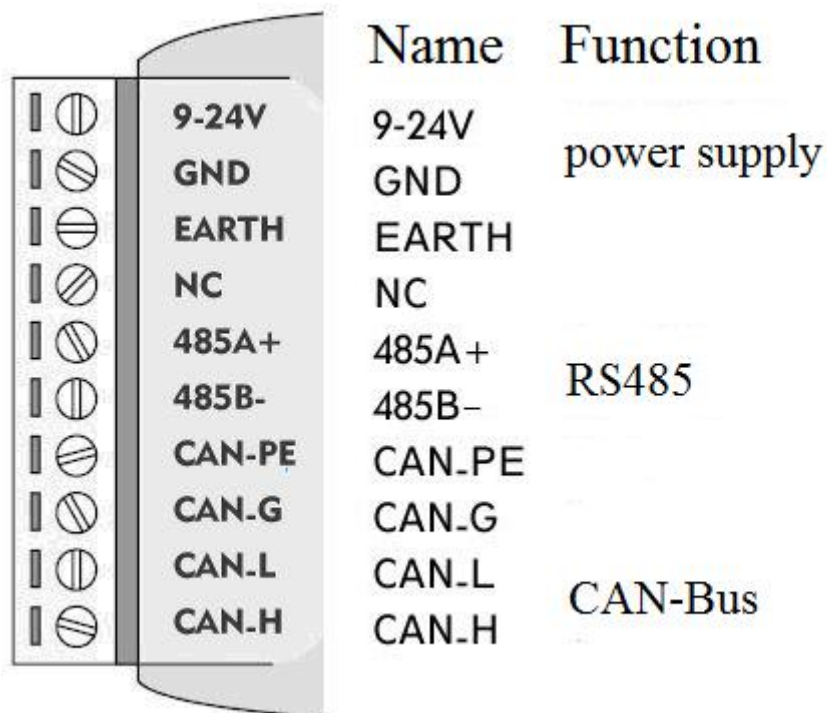

Figure 2.2 GCAN-207 terminal definition

Note: The CAN-Bus network adopts topological structure, only the two furthest terminal need to connect 120Ω terminal resistance between CAN_H and CAN_L. For branch connection, its length should not be more than 3 meters. CAN-Bus nodes connection as shown in figure 2.3.

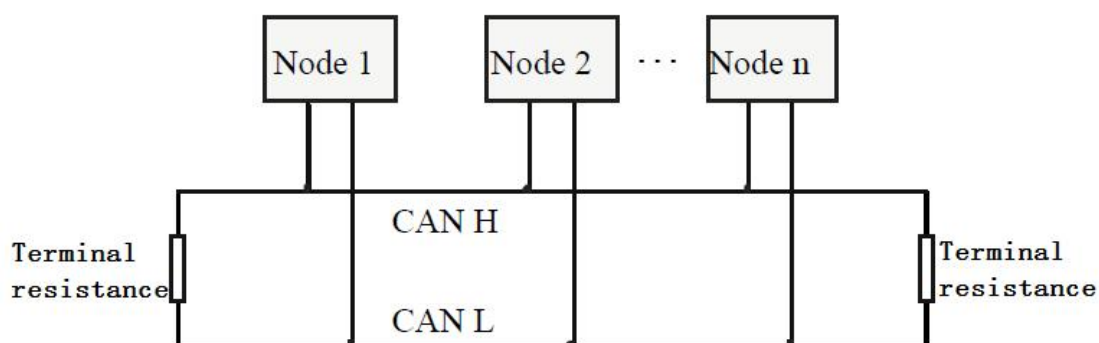

Figure 2.3 CAN-Bus network

2.4 System LED

GCAN-207 converter with one PWR indicator, one COM indicator, one CAN indicator to indicate the converter status. More functions are shown in table 2.1.

Indicator	State	Meaning
PWR	ON	Power supply normal
	OFF	Power supply error
COM	OFF	No data
	Blinking	COM data transmission
CAN	OFF	CAN-Bus no data
	Red	CAN-bus error
	Blinking	CAN-Bus data transmission

Table 2.1 GCAN-207 converter LED state

If PWR indicator lights up, it indicates that you plug GCAN-207 converter into an electricity supply, and the system is initialized.

Otherwise, a system power failure or system error has exist.

When Serial-bus data is being transmitted, COM indicator will blinking.

When CAN-bus data is being transmitted, CAN indicator will blinking in green.

If CAN error occurs, CAN indicator will turn red.

When COM and CAN indicator blink alternately, it means the converter is in configuration mode.

3 Configuration instructions

3.1 Ready to configure

First, power on the converter, then using a thin stick click reset button at the side of the DB9 interface converter. Converter of COM light and CAN light flashing interactively, that converter to enter configuration mode. After connecting the converter of the RS232 interface and PC, enter the device manager to find the serial port Number.

Note: the serial NO.(COM) can be modified in device manager interface, GCAN-207 can only be configured through the RS232 interface.

3.2 Software connection

When the GCAN-207 converter enter the configuration mode and in connection with PC via a serial port, open the“RS232CAN-Config”software as shown in figure 3.1.



Figure 3.1 RS232CAN-Config main interface

3.3 Configure transformation parameters

Transformation parameters interface as shown in figure 3.2. GCAN-207 supports three kinds of working mode: transparent conversion, transparent conversion with identity and format conversion. GCAN-207 supports three kinds of conversion direction: bidirectional switching、CAN→serial port、serial port→CAN. Working mode and conversion direction can be modified in “转换参数”.



Figure 3.2 Working mode setting

3.3.1 Transparent conversion

GCAN-207 will convert the data to the other side immediately if GCAN-207 receives data without adding data and make changes to the data.

“允许 CAN 帧信息转发到串行帧中” (Allows CAN frame information to be forwarded to the serial frame) and “允许 CAN 帧标识转发到串行帧中” (Allows CAN frame ID to be forwarded to the serial frame) are only available in Transparent conversion mode.

3.3.2 Transparent conversion with identity

Transparent conversion with identity will convert the data of Serial frame by adding an address into the CAN frame ID . The start position and length of the address can be configured.

3.3.3 Format conversion

Format conversion is the simplest using method. The data format is defined in 13 bytes, which include all information about CAN frame.

3.4 Configure serial port parameters

Serial port parameter settings shown as Figure 3.3, GCAN-207 supports serial port baud rate(串口波特率)from 600bps~115200bps, the other parameters do not need to set up.

GCAN-207 can switch modes of RS232 or RS485 in serial port parameters(“串口参数”). Click “写配置” (download) after the completion of the configuration, after that you should power-on again.

转换参数 串口参数 CAN参数

参数

串口波特率: 57600 bps: 数据长度: 8

奇偶校验: 无 停止位: 1

模式

模式切换: RS485模式

设备类型: CANCom 默认值 读配置 写配置

固件版本: 3.14

Figure 3.3 Serial port parameter Settings

3.5 Configure CAN parameters

CAN parameter setting is shown as Figure3.4. Users can set basic information of CAN-Bus, including CAN baud rate(波特率) and CAN frame type(帧类型).

CAN baud rate supports: 1000K, 500K, 250K, 200K, 125K, 100K, 50K, 20K, 10K, 5K.

CAN frame type supports: standard frame(标准帧), extension frame(扩展帧). CAN frame ID(“发送标识符”) only available in Transparent conversion mode.

GCAN-207 can enable the filter by checking “滤波器使能”. After setting the range and the mode, click add(“添加”).

转换参数 | 串口参数 | CAN参数

初始化参数

波特率: 1000k bps 帧类型: 标准帧

自定义数据: 0x (HEX) 发送标识符: 0x 181 (HEX)

滤波参数 (12组) 滤波器使能

模式	起始帧ID (HEX)	结束帧ID (HEX)
标准帧滤波	00000201	00000204

模式: 标准帧滤波 起始ID: 0x 00000201 结束ID: 0x 00000204

添加 删除

设备类型: CANCom 默认值 读配置 写配置

固件版本: 3.14

Figure3.4 CAN parameter setting

When the configuration is completed, click “写配置” to download the converter parameters.

When the parameters download is complete, users need to power-on again to effect the new configuration.

4 Examples

4.1 Transparent conversion

1. Serial port→CAN

GCAN-207 will send the serial data to CAN-Bus immediately if GCAN-207 receive the serial data.

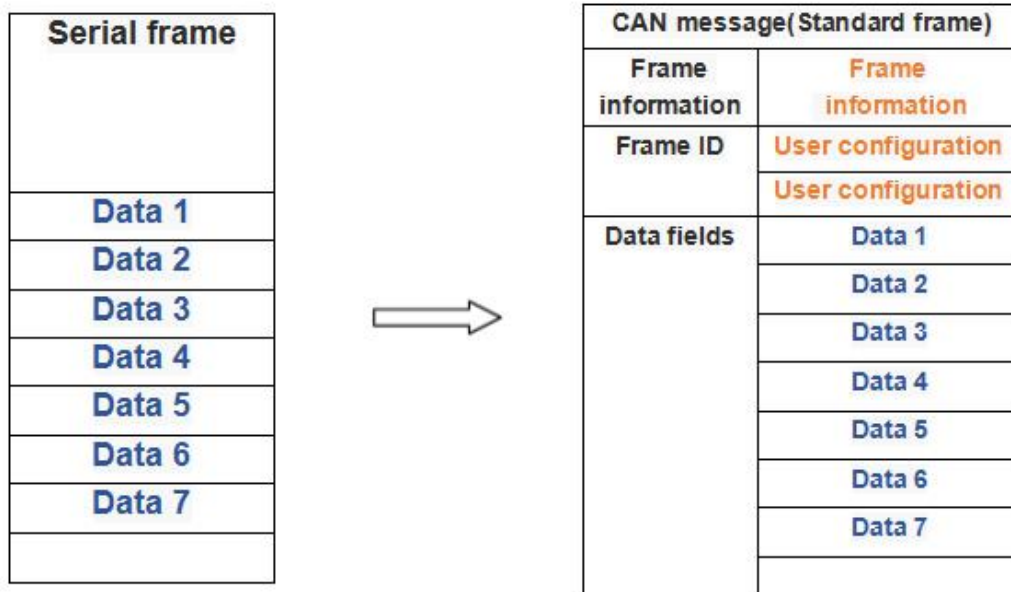

E.g. Serial data 11 22 33 44 55 66 77 88 converts to CAN-Bus. Frame ID is the configuration for “发送标识符” which users have set. Frame data is 11 22 33 44 55 66 77 88.

2. CAN→Serial port

GCAN-207 will send the CAN data to serial port immediately if GCAN-207 receive the CAN data.

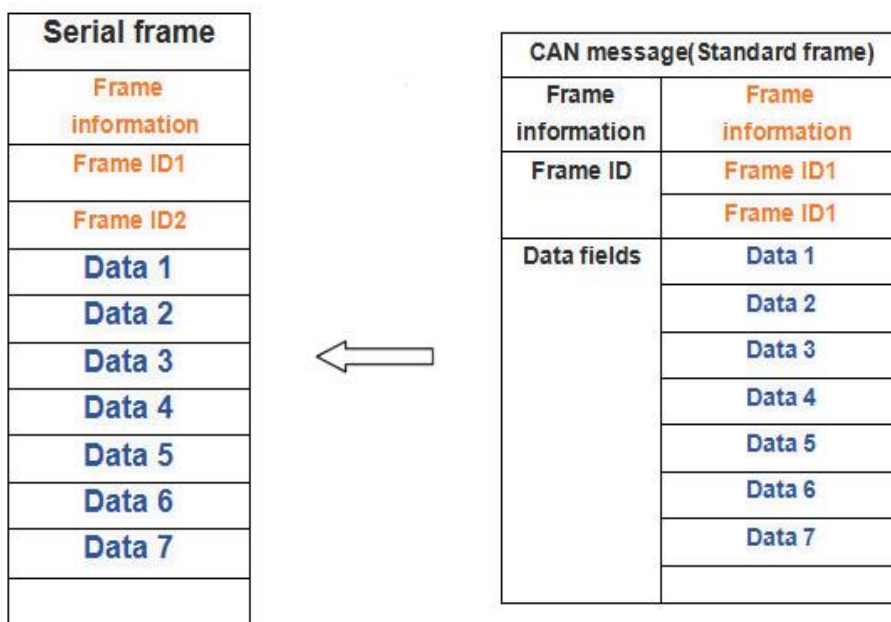

E.g.: Check “允许 CAN 帧信息转发到串行帧中” and “允许 CAN 帧标识转发到串行帧中” which means the CAN frame information(帧信息) and the frame ID (帧标识) will display in the serial frame.

CAN frame is standard data frame. Frame ID is 00 01. Frame data is 11 22 33 44 55 66 77 88. GCAN-207 converts to Serial port. Serial data is 08 00 01 11 22 33 44 55 66 77 88.

4.2 Transparent conversion with identity

Transparent with identity transformation is the special usage of Transparent conversion.

1. Serial port→CAN

Users can set the start position address and the length of the CAN frame ID in the configuration.

E.g. : If the CAN frame ID starting position address is 1, the length is 2 in the Serial frame.

Serial frame data is 01 23 33 44 55 66 77 88. GCAN-207 converts to CAN. CAN frame ID is 123, and frame data is 33 44 55 66 77 88.

2. CAN→Serial port

E.g. : If the CAN frame ID starting position address is 1, the length is 3 in the Serial frame (Extension frames) . Conversion is shown as Figure below.

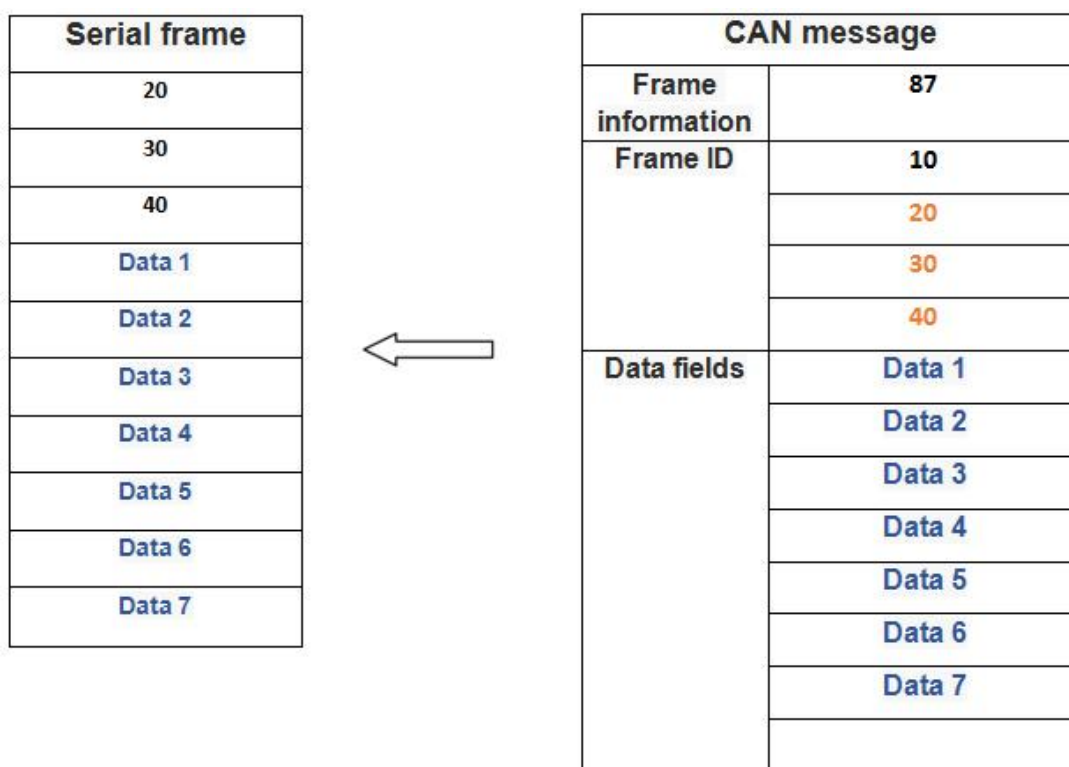

4.3 Format conversion

Each CAN frame of GCAN-207 contains 13 bytes, which include CAN frame information+ frame ID + frame data.

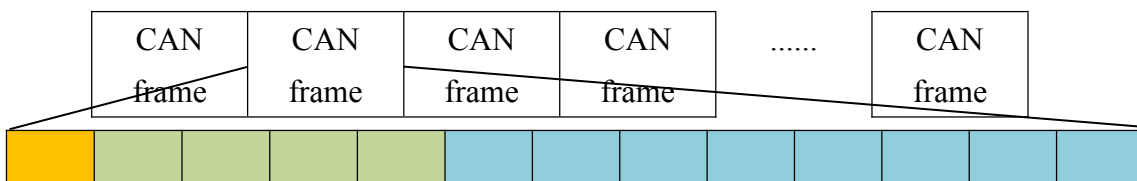

Frame information: Length 1 byte, include some of the frame information, such as type, length, etc.

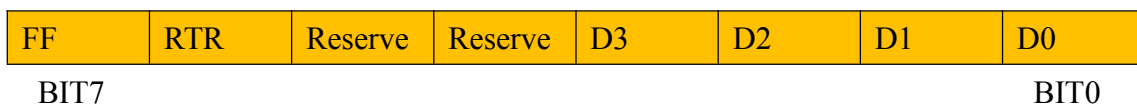

FF: Standard frame and extended frame identification, 1 for extension frames, 0 for the standard frame.

RTR: Remote frame and data frame identification, 1 for remote frame, 0 for the data frame.

Reserve: Retains the value is 0.

D3~D0 : Data length, data which CAN frame length.

Frame ID: 4 bytes in length, standard frame effective bit are the first 11 bits, effective frame effective bit are the first 29 bits.

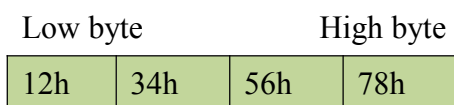

Frame ID: 0x12345678

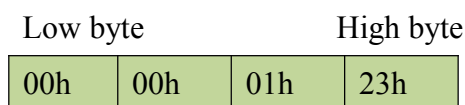

Frame ID: 0x123

Frame data: 8 bytes in length, the effective length of the frame information
D3 ~ D0 the values of the decision.

DATA1							DATA8
11h	22h	33h	44h	55h	66h	77h	88h

Above, for example of 8 bytes

DATA1							DATA8
11h	22h	33h	44h	55h	00h	00h	00h

Above, for example of 8 bytes

E.g.: Serial port → CAN

The following example is an extended data frame, frame ID is 0x12345678, contains 8 bytes valid data representation (11h,22h,33h,44h,55h,66h,77h,88h).

88h	12h	34h	56h	78h	11h	22h	33h	44h	55h	66h	77h	88h
-----	-----	-----	-----	-----	-----	-----	-----	-----	-----	-----	-----	-----

The following example is a standard data frame, frame ID is 0x123, contains 8 bytes valid data representation (11h,22h,33h,44h,55h).

05h	00h	00h	01h	23h	11h	22h	33h	44h	55h	00h	00h	00h
-----	-----	-----	-----	-----	-----	-----	-----	-----	-----	-----	-----	-----

Note: Each frame is fixed on 13 bytes, insufficient must fill 0, otherwise will cause communication error.

5 Technical Specifications

Connection	
Serial interface	RS232: DB9; RS485: Terminal blocks
CAN interface	Terminal blocks
Interface characteristics	
Serial interface	Standard RS232/RS485 interface
Serial port baud rate	600bps~115200bps
CAN interface	ISO 11898 standard, CAN2.0A/B
CAN baud rate	1000K, 500K, 250K, 200K, 125K, 100K, 50K, 20K, 10K, 5K
Electrical isolation	1500V, DC-DC
CAN termination resistors	None. You can add it between CAN_H and CAN_L if you need it.
Power supply	
Power supply voltage	+9~30V DC
The power supply current	Maximum 20mA (24V DC)
Environmental testing	
Working temperature	-40°C~+85°C
Working humidity	15%~90%RH, no condensation
EMC test	EN 55024:2011-09 EN 55022:2011-12
Protection grade	IP 20
The basic information	
Outline size	112mm *70mm *25mm
Weight	100g

Sales and service

Shenyang Guangcheng Technology Co., Ltd.

Address: Industrial Design Center, No. 42 Chongshan
Middle Road, Huanggu District, Shenyang
City, Liaoning Province.



QQ: 2881884588

E-mail: 2881884588@qq.com

Tel: +86-024-31230060

Website: www.gcgd.net

Sales and service Tel: +86-18309815706

After - sales service telephone Number: +86-13840170070

WeChat Number: 13840170070