

GCAN-205

Modbus/TCP to CAN converter

User Manual



Document version: V3.11 (2017/07/20)

Contents

1 Introduction.....	3
1.1 Overview.....	3
1.2 Properties at a glance.....	3
2. Installation.....	5
3. Connection and use.....	6
3.1 Configure with PC connections.....	6
3.2 Connect to Ethernet.....	7
3.3 Connect to CAN-Bus.....	7
3.4 System LED.....	8
4. Configuration instructions.....	9
4.1 Basic parameter configuration.....	9
4.2 Receive CAN data mapping table.....	11
4.3 Transmit CAN data mapping table.....	11
4.4 Download to the Flash of GCAN-205.....	12
4.5 Save GCAN-205 converter parameters.....	12
5. Examples.....	13
5.1 Read the received CAN frame.....	13
5.2 Write the CAN frame to be sent.....	14
6. Technical specifications.....	16
Sales and service.....	17

1. Introduction

1.1 Overview

The GCAN-205 is a CAN-Bus and ethernet converter. GCAN-205 converter ethernet-side integrated Modbus TCP protocol. GCAN-205 can convert the data between CAN-Bus and Modbus TCP. With this converter, equipment that used Modbus TCP protocol can connect to CAN-Bus without changing the hardware structure, this makes multi-Bus interconnection very flexible, and extends the application scope of CAN-Bus.

1.2 Properties at a glance

1.2.1 Hardware

- High-speed 32-bit processor
- Embedded hardware watchdog timer
- Power supply voltage: DC 24V, maximum current: 40mA
- Electrostatic discharge immunity level: contact discharge $\pm 2KV$, air discharge $\pm 15KV$
- Electrical fast transient burst immunity level: $\pm 1KV$
- Surge immunity level: $\pm 1KV$
- Operating temperature range: $-40\text{ }^{\circ}C \sim +85\text{ }^{\circ}C$
- Operating humidity range: 5% to 95% RH no condensation
- Dimensions: 113mm * 100mm * 21mm
- Standard DIN rail mounting, designed for industrial design

1.2.2 CAN

- Integrated 1 CAN-Bus interface with terminal
- CAN-Bus signals include: CAN_H, CAN_L, CAN_GND
- CAN-Bus supports CAN2.0A and CAN2.0B frame format, conform to ISO/DIS 11898 standards
- CAN-Bus baud rates range from 5Kbps to 1Mbps
- CAN-Bus isolation converter insulation voltage: DC 1500V

1.2.3 Ethernet

- RJ45, support 10 / 100M adaptive
- Modbus slave support function code: 03H, 04H, 06H, 16H
- Support static or dynamic IP access
- Support heartbeat and timeout interrupt function
- The working port is fixed, the target IP and the target port can be set
- After the network is disconnected, the connection resource is automatically restored and the TCP connection is established reliably
- Support protocols include EtherNET, ARP, IP, ICMP, UDP, DHCP, DNS, TCP
- Compatible with SOCKET work (TCP Server, TCP Client, UDP, etc.), the host computer communication software follows the standard SOCKET rules

2. Installation

The GCAN-205 interface information is shown in Figure 2.1. The power interface is defined in Table 2.1.



Figure 2.1 GCAN-205 interface

DC24V		Description
1	+	24V DC+
2	-	GND
3	NC	NC
4	PE	shield

Table 2.1 Power Interface

3. Connection and use

The working principle of GCAN-205 is shown in Figure 3.1.

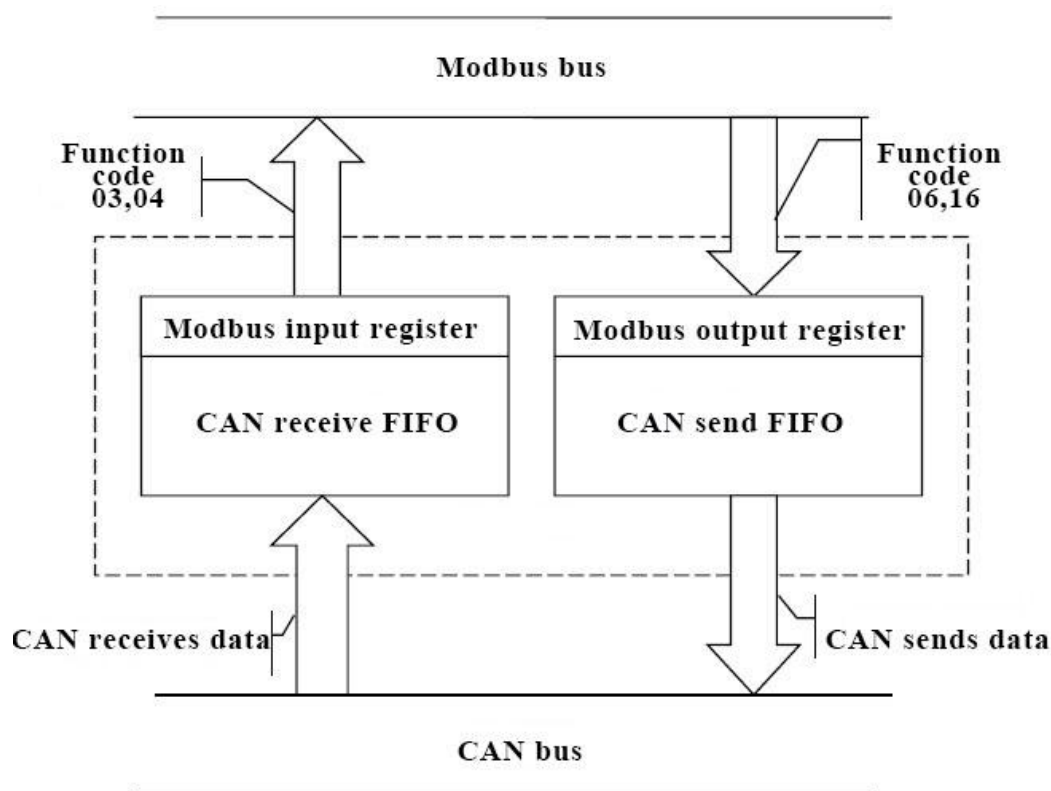

Figure 3.1 Working principle of GCAN-205

3.1 Configure with PC connections

The GCAN-205 converter uses a 24V DC power supply. By using the "GCAN205-ModbusTcp-CAN-configV3.CH" software, the GCAN-205 converter can configure the working model and the parameter. GCAN-205 only supports communication between Modbus / TCP-CAN, other protocols are not supported.

3.1.1 Restore the factory Settings

GCAN-205 converter factory IP: 192.168.1.10. If users have changed the IP, users can operate the DIP switch to reset the parameters.

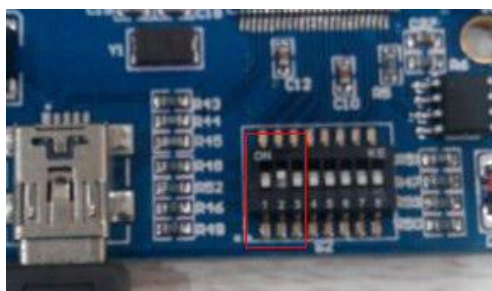

Figure 3.2 GCAN-205 converter DIP switch position

Operation method: first open the converter shell to find the switch shown in Figure 3.2. Second switch the No. 2 to "ON", then supply the power, waiting for 3 seconds. After the "SYS" indicator flashing, turn off the power and switch back to "OFF". Now, the converter has been restored to the factory default state, the system factory IP: 192.168.1.10.

Please note: after the converter has been reset, all parameter settings and mapping table settings will be cleared. Please be careful.

3.1.2 Change the IP address for PC

PC IP and GCAN-205 IP must be in the same network segment.

For example: converter IP: 192.168.1.10, PC IP: 192.168.1.1.

Please note: PC IP can not be the same as the converter IP.

3.2 Connect to Ethernet

The ethernet interface of the GCAN-205 converter integrates a 10 / 100M adaptive ethernet chip. The converter conforms to the ethernet standard protocol specification.

3.3 Connect to CAN-Bus

In practical use, users only need to connect the CAN_H to CAN_H and CAN_L to CAN_L, then communication can be realized.

The CAN-Bus network adopts topological structure, only the two furthest terminal need to connect 120 Ω terminal resistance between CAN_H and CAN_L. For branch connection, its length should not be more than 3 meters. CAN-Bus nodes connection as shown in figure 3.3.

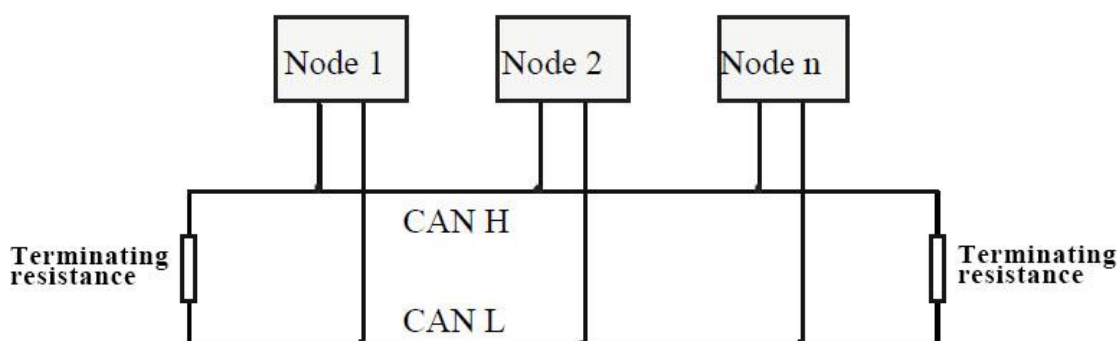

Figure 3.3 CAN-Bus network

Note: CAN-Bus using ordinary twisted pair. The relationship between the bus length and baud rate is shown in Table 3.1.

Baud rate	Bus length
1 Mbit/s	40m
500 kbit/s	110m
250 kbit/s	240m
125 kbit/s	500m
50 kbit/s	1.3km
20 kbit/s	3.3km
10 kbit/s	6.6km
5 kbit/s	13km

Table 3.1: Baud rate and maximum bus length reference table

3.4 System LED

GCAN-205 converter with one SYS indicator, one DAT indicator. More functions are shown in table 3.2.

Indicator light	Color	Indicates the state
SYS	Green	System operation instructions
DAT	Green	Data conversion transfer instructions

Table 3.2: Indicators for the GCAN-205 converter

After power on the converter, the SYS indicator light indicates that power is being supplied and the system is initializing; otherwise, it indicates power failure or an error occurred.

If the bus has data transmission, DAT indicator will flash.

Indicator light	Status	Indicates the state
SYS	Blinking	System initialization pass, standby state
	OFF	System initialization failed
DAT	Blinking	There is data transmission between the buses
	OFF	There is no data transmission between the buses

Table 3.3: Status of the GCAN-205 converter indicator

4. Configuration instructions

4.1 Basic parameter configuration

The GCAN-205 converter can be configured by using the "GCAN205-ModbusTcp-CAN-configV3.CH" software, including the basic parameters such as operating mode, working port, target port, target IP, CAN operating mode, CAN baud rate.

4.1.1 Connect the GCAN-205 converter to the computer

1. Power on the converter, and connect the converter to the computer with a network cable
2. Open the "GCAN205-ModbusTcp-CAN-configV3.CH" software



"Connect" - connect equipment

"Upload" - read out the configuration information in the converter

"DownLoad" - download the configuration information to the converter Flash

"Open" - open and read the configuration information file in the PC

"SaveAs" - save the configuration information file to your computer

3. Click "Connect" and enter the IP address of GCAN-205
4. After connecting, click "UpLoad" to upload the parameters of the converter to the computer. After that, the following information will be displayed

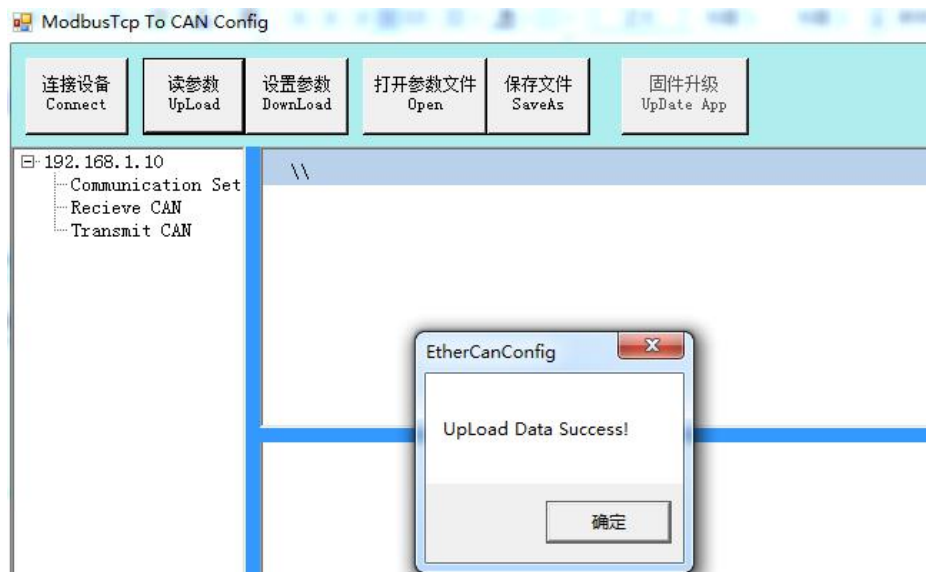

4.1.2 CAN baud rate setting

"CAN Baudrate" can set the baud rate of the CAN-Bus, the corresponding table is as follows:

Parameter	Baud rate
0	1000K
1	800K
2	666K
3	500K
4	400K
5	250K
6	200K
7	125K
8	100K
9	80K
10	50K
11	40K
12	20K
13	10K
14	5K

4.1.3 Ethernet address settings

"IP Address" - set the IP address of the converter

"Subnet Mask" - set the subnet mask

"GateWay" - set the communication gateway

When the parameter is modified, the corresponding unit becomes red

[Product data sheet](#)

4.2 Receive CAN data mapping table

Click "Receive CAN" in the left side of the interface to display the following interface.

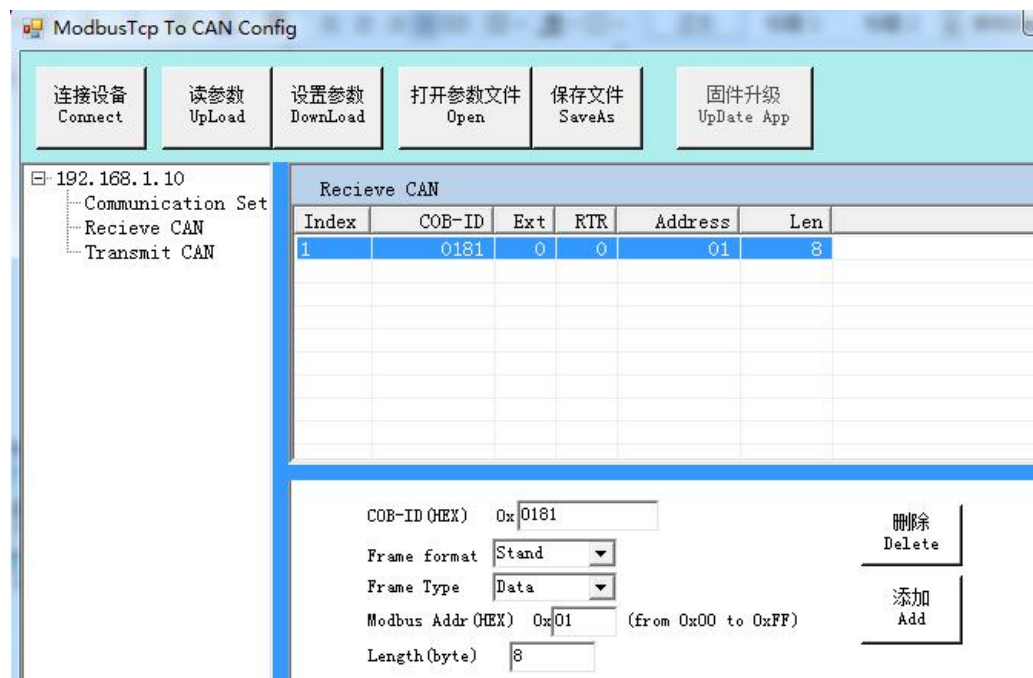

COB-ID: set the frame ID of the CAN-Bus

Frame Format: set the frame format

Frame Type: set the frame type

Modbus address: set the Modbus register first address

Length: CAN frame data length, the maximum value of 8

4.3 Transmit CAN data mapping table

Click "Transmit CAN" project and add data mapping group, at least 32 groups.

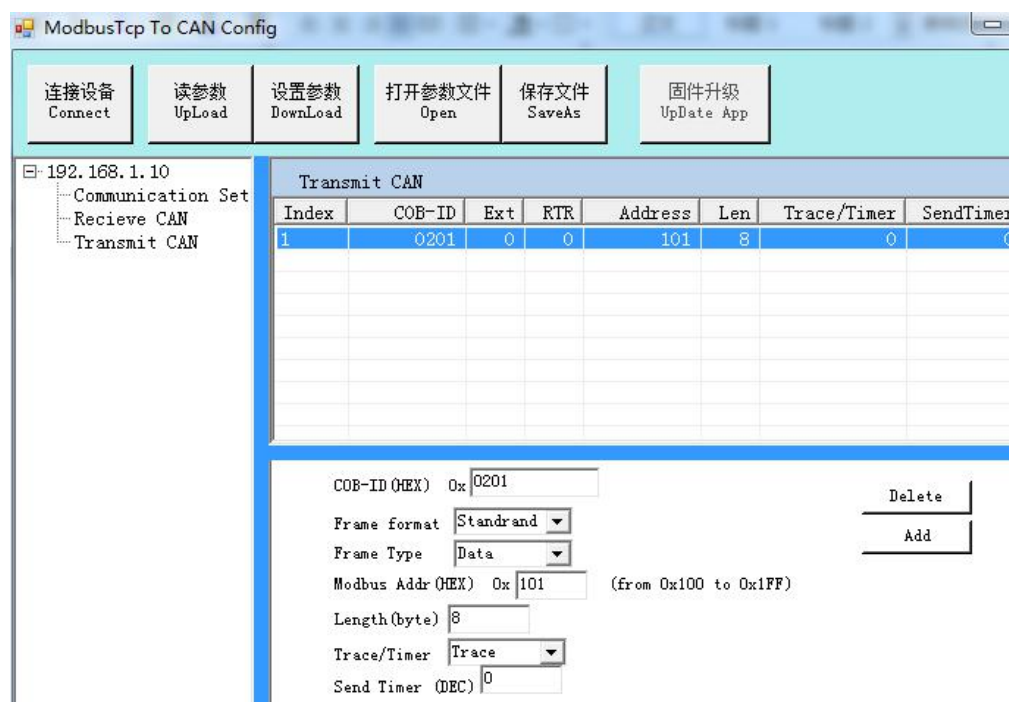

COB-ID: set the frame ID of the CAN-Bus

Frame Format: set the frame format

Frame Type: set the frame type

Modbus Address: set the Modbus register first address

Length: CAN frame data length, the maximum value of 8

Trace mode: If GCAN-205 receives data from Modbus master, it will transmit the data to the CAN-Bus.

Timer mode: at intervals, GCAN-205 transmit the data to the CAN-Bus. The time interval can be set with decimalism below, with unit ms.

4.4 Download to the Flash of GCAN-205

When the configuration is complete, users can click on the "DownLoad" to write data into the converter Flash. When the data is written successfully, you need to re-power to enable the new settings.

4.5 Save GCAN-205 converter parameters

Configuration parameters can be saved to PC by "SaveAs". The configuration file can be opened again.

NOTE: after the configuration is downloaded successfully, you need to re-power the converter to enable the new configuration.

5. Examples

Users can send the Modbus instruction through the network debugging software in the CD. Please choose the TCP Client mode and the remote host address is 192.168.1.10:502 (IP address for the factory settings, can be modified; port number can not be modified).

Please note: check the "Receive as hex" and "Send as hex" when using the software Network Debugging Assistant.

5.1 Read the received CAN frame

For example:

Modbus slave address: 1

Modbus register first address: 0x01 (factory setting)

Function code: 03

Frame format: standard frame

Frame ID: 0x181

CAN frame data: 0x01, 0x02, 0x03, 0x04, 0x05, 0x06, 0x07, 0x08

Modbus master sends request frame:

00 00 00 00 00 06 01 03 00 01 00 04

Master send	The number of bytes	Example (Hex)
Transmission identifier	2bytes	00 00
Protocol identifier	2bytes	00 00
Data length	2bytes	00 06
Converter address	1bytes	01
Function code	1bytes	03
Start address	2bytes	00 01
Number of registers	2bytes	00 04

Response frame of GCAN-205:

00 00 00 00 00 0B 01 03 08 02 01 04 03 06 05 08 07

Slave send	The number of bytes	Example (Hex)
Transmission identifier	2bytes	00 00
Protocol identifier	2bytes	00 00

Data length	2bytes	00 0B
Converter address	1bytes	01
Function code	1bytes	03
Response bytes	1bytes	08
Register value	8bytes	02 01 04 03 06 05 08 07

At this point, the GCAN-205 converter receives a data frame with CAN ID of 0x181.

5.2 Write the CAN frame to be sent

For example:

Modbus slave address: 1

Modbus register first address: 0x101(decimal value is 257, factory setting)

Function code: 16(10H)

Frame format: standard frame

Frame ID: 0x201

CAN frame data: 0x01, 0x02, 0x03, 0x04, 0x05, 0x06, 0x07, 0x08

Modbus master sends request frame:

00 00 00 00 0F 01 10 01 01 00 04 08 02 01 04 03 06 05 08 07

Master send	The number of bytes	Example (Hex)
Transmission identifier	2bytes	00 00
Protocol identifier	2bytes	00 00
Data length	2bytes	00 0F
Converter address	1bytes	01
Function code	1bytes	10
Start address	2bytes	01 01
Number of registers	2bytes	00 04
Response bytes	1bytes	08
Register value	8bytes	02 01 04 03 06 05 08 07

Response frame of GCAN-205:

00 00 00 00 06 01 10 01 01 00 04

Slave send	The number of bytes	Example (Hex)
Transmission identifier	2bytes	00 00
Protocol identifier	2bytes	00 00
Data length	2bytes	00 06
Converter address	1bytes	01
Function code	1bytes	10
Start address	2bytes	01 01
Number of registers	2bytes	00 04

At this point, the CAN terminal of other converters receive a data frame with a CAN ID of 0x201 from the Modbus side.

6. Technical specifications

Connection	
Ethernet	RJ45
CAN interface	OPEN3 terminal blocks
Interface characteristics	
Ethernet interface	10 / 100M adaptive
CAN interface	Follow the ISO 11898 standard to support CAN2.0A / B
CAN baud rate	5Kbit/s~1Mbit/s
Electrical isolation	1500V, DC-DC
120 ohm resistance	Not integrated
Power supply	
Voltage	+24V DC
Supply current	Maximum 40mA
Environmental testing	
Operating temperature	-40°C~+85°C
Working humidity	15%~90%RH, No condensation
EMC testing	EN 55024:2011-09 EN 55022:2011-12
Protection class	IP 20
The basic information	
Outline size	113mm *100mm *21mm
Weight	120g

Sales and service

Shenyang Guangcheng Technology Co., Ltd.

Address: Industrial Design Center, No. 42 Chongshan
Middle Road, Huanggu District, Shenyang
City, Liaoning Province.



QQ: 2881884588

E-mail: 2881884588@qq.com

Tel: +86-024-31230060

Website: www1.gcanbox.com

Sales and service Tel: +86-18309815706

After - sales service telephone Number: +86-13840170070

WeChat Number: 13840170070